



MIKRON G05™  
High volume automation solutions  
for the assembling of products





THE G05 PRODUCT FAMILY OFFERS CUSTOMIZED  
PRODUCTION SOLUTIONS BASED ON **HIGH  
PERFORMANCE ASSEMBLY** PLATFORMS  
COMBINED WITH FLEXIBLE FEEDING SYSTEMS.  
THE G05 IS OUR CONTRIBUTION TO THE  
SUCCESS OF YOUR ASSEMBLY PROJECT





# THE MIKRON G05™ – STANDARD PLATFORM FOR YOUR AUTOMATION SOLUTION

The Mikron G05 linear assembly cell is based on a range of standardized building blocks which offer flexibility and modularity. The platform makes use of a central drive and cam based pick & place units for all primary motions. This guarantees perfect synchronization between the working units and the pallet indexing system. Each assembly step is followed by a systematic check to ensure continuous and consistent quality. Multiple cells can

be linked together depending on project requirements which allows full layout flexibility. The linear concepts gives Improved accessibility for material flow both to and from the assembly line and also very quick access for operators and maintenance personal. The use of manual working stations, semi- and fully automatic cells offer progressive investment from pilot to fully automatic lines.



Mikron G05 1 Module



Mikron G05 2 Modules

## YOUR BENEFITS

### Short lead times

It is now necessary to be on the market much quicker. The basis for this is modularity – standardized chassis, process module and unit and logistic module. In addition to standardized mechanical and software functions too.

### Rapid change-over, modular adaptability

Mikron G05 is able to combine single or double module cells with manual working stations. Cells can be linked together, front and back, in order to meet restrictions on customer production floor. The individual process modules can be removed from the cell and tested off-line by technicians.

### Progressive investment

Quick market changes with a high level of responsiveness. The concept with its manual, semi-automatic and fully-automatic cells make it possible to react module by module to changes in the marketplace.

### Clean room compatibility

From the outset, the G05 takes into account the special conditions for clean room ISO 7 (class 10,000) applications : featuring elements with lifetime lubrication, high-quality stainless steel and aluminium,

protective coverings over conveyors, easy accessibility and cleaning.

### Pharma and medical qualification

Production processes all need to be verified by means of very strict regulations. To meet these specific needs, Mikron Automation ensures that, right from the concept stage, its platforms are fully compliant with the latest certification standards in force. Specific emphasis has been put on ergonomic and cleaning tooling to meet the GMP norms. Moreover, the basic machine – hardware and software – is validated according to GAMP 5 and is 21 CFR part 11 compatible.

### Easy programming and operation

Effortless operation, rapid learning and system mastery are accessible through the touch screen HMI (Human Machine Interface). The control and inspection software is specially designed for ease of use. The simple interface makes it easy to configure standard functions.

### Process integration expertise

With 40 years of process experience, Mikron has mastered a number of very complex assembly and test processes. A vast library of standard processes assures the quality, stability and reliability of your solution. One of the Mikron core competences is to integrate high speed processes even when they are very complex.

## 5 REASONS TO WORK WITH MIKRON

1. Proven know-how – over 100 years of experience with precision machinery – close to 40 years in assembly
2. Reliable and technical production solutions with high added value – mastery of complex processes, standardized and proven automation platforms
3. Short delivery time – quicker time to market
4. Mikron worldwide organization is committed to your project success – from project fulfillment to 24/7 customer service
5. Long-term partnership – industry references

# THE G05 PLATFORM CONCEPT IS BASED ON STANDARD BUILDING BLOCK ELEMENTS; A STABLE AND PROVEN BASE MACHINE TO BUILD COMPLEX HIGH SPEED AUTOMATION SOLUTIONS

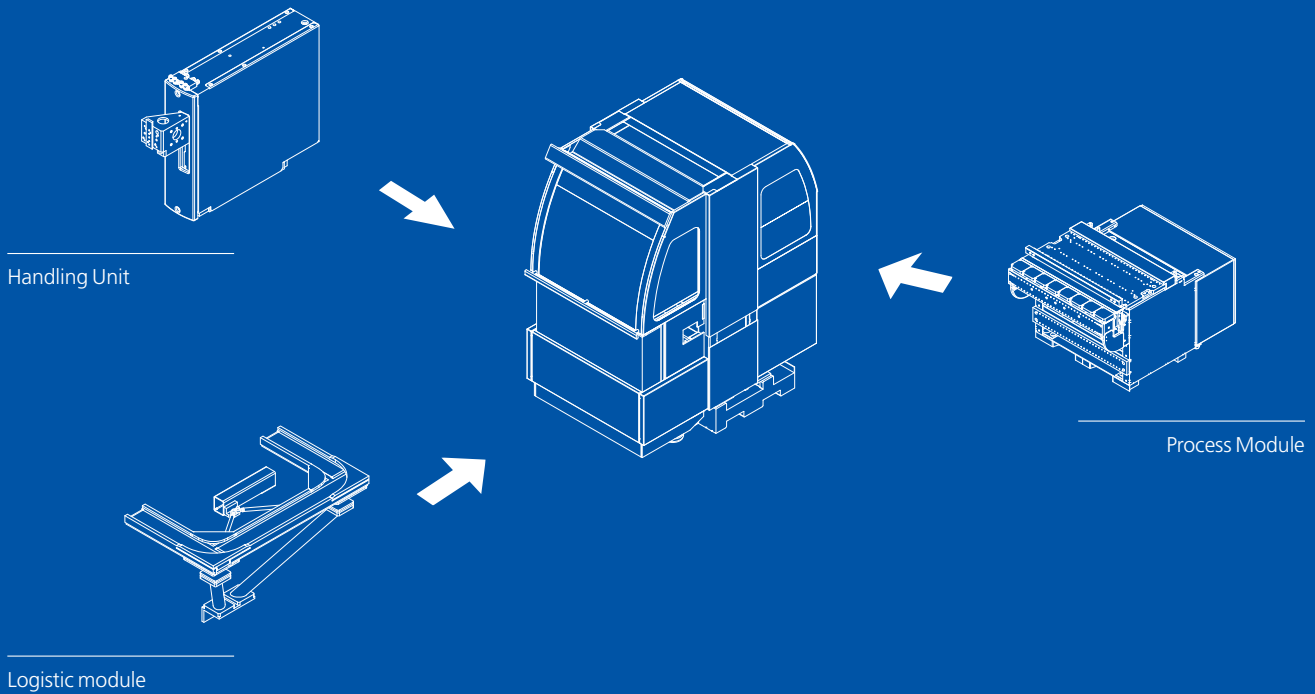

## TECHNICAL SPECIFICATIONS

Standardized linear concept with power and free pallets, servo indexed and mechanically locked inside the process cell

		STANDARD PLATFORMS	
		1 MODULE	2 MODULES
Assembled product size	Products that can be hold in a hand	✓	✓
Working area	One side of the module	✓	✓
Pallet size	60, 120, 160 or 240 mm	✓	✓
Assembly Speed	up to 100 cycles/min Multiple assemblies per pallet	✓	✓
Indexing repeatability	+/- 0.01 mm	✓	✓
Number of stations	Handling Unit 120mm (60 mm)	8 (16)	16 (32)
Dimensions	Length x Width x Height (mm)	1235 x 1816 x 2220	2195 x 1816 x 2220
Control System	PC B&R, PLC Allen-Bradley or PLC Siemens	✓	✓
Process Integration	Mechanical, pneumatic or servo driven handling and process units, Cartesian robot unit, manual working stations, customer project-specific processes, feeders and palletizers	✓	✓
Cleanroom	The standard cell is compatible for cleanroom ISO 7 (class 10,000)	✓	✓
Validation	Validated base machine according to GAMP 5 The standard cell is conformed to CE marking	✓	✓

# SOLUTIONS ADAPTED TO YOUR NEEDS: FROM PILOT TO FULLY AUTOMATED LINE

The concept with its manual, semi automatic and fully automatic cells make it possible to react module by module to changes in the marketplace.

It is possible to invest as needed, based on product volume requirements; the assembly system grows to meet market demands.

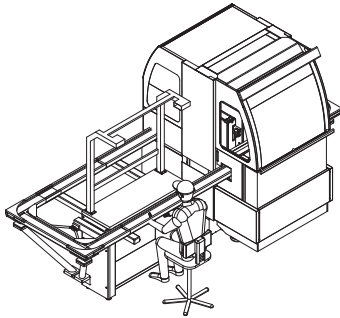

Manual G05 assembly line

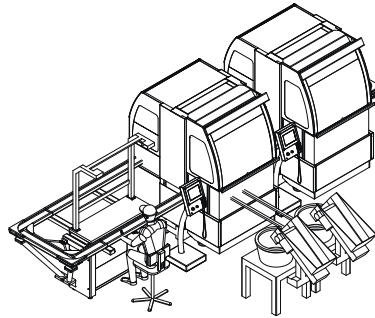

Semi-automated G05 assembly line

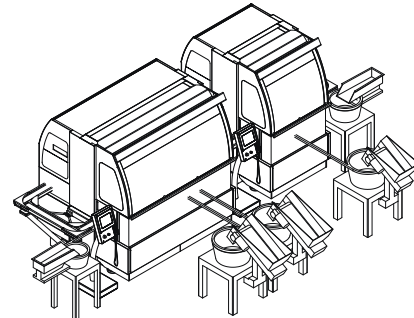

Fully-automated G05 assembly line

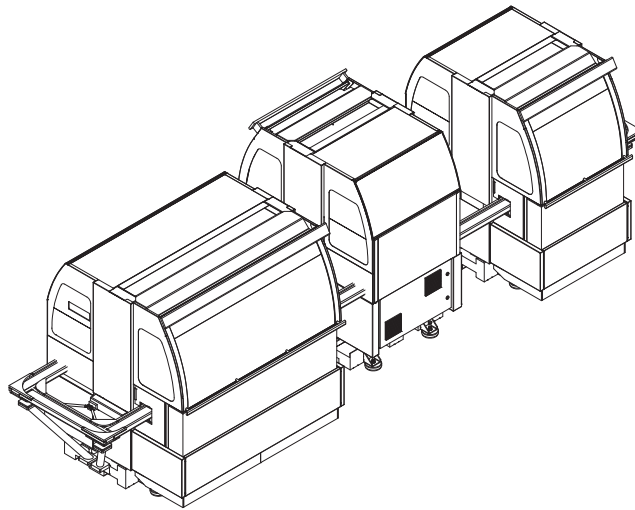

G05 2 modules front - G05 1 module back - G05 1 module front

## FEEDING SOLUTIONS

Polyfeed is a perfect fit for Mikron's high performance assembly systems. Polyfeed is a flexible feeding system based on the use of visual recognition and vertical vibration systems to identify parts in their various forms and positions.

Mikron supplies a highly standardized tray handler capable of dealing with a range of applications from single tray to multiple stack. The standardized building blocks concept allows easy integration of additional in-tray process such as lid handling, inkjet printing, quality inspection



Mikron Polyfeed



Mikron Tray Handler

## ABOUT US

Mikron Automation is headquartered in Boudry (Neuchâtel), in a region that is regarded as the heart of the Swiss watchmaking industry. To date, Mikron Automation has installed more than 3,000 assembly and testing systems worldwide. Its international customers operate in the following markets: Pharma and Medical Devices, Automotive Supply, Electrical/Electronics, Consumer Goods and Construction/Building. Mikron Automation employs around 590 people at its sites in Boudry (Switzerland, headquarters), Berlin (Germany), Denver (USA), Singapore and Shanghai (China).

Mikron SA Boudry  
Route du Vignoble 17  
2017 Boudry  
Switzerland

Tel. +41 32 843 11 11  
mbo@mikron.com

Mikron Corp. Denver  
8100 S Potomac St.  
Englewood CO 80112  
USA

Tel. +1 303 364 5222  
mde@mikron.com

Mikron Berlin GmbH  
Landsbergerstrasse 252  
12623 Berlin  
Deutschland

Tel. +49 30 9830 7211  
mab@mikron.com

Mikron Singapore Pte Ltd  
61 Tai Seng Ave, #05-11  
Singapore 534167

Tel. +65 6299 1589  
msi@mikron.com

Mikron Industrial  
Equipment (Shanghai) Co., Ltd.  
No 358, 3rd Factory  
Dong Ye, Dong Jing Town,  
Song Jiang District  
Shanghai China 201619  
Tel. +86 21 6767 9681  
msh@mikron.com

[www.mikron.com/automation](http://www.mikron.com/automation)